



# ADA Single Stall Shower Trailer

The Royal Restrooms ADA Single Stall Shower Trailer which is furnished with a toilet, sink and shower, is designed to accommodate groups of people including individuals with disabilities. The ADA (Americans with Disabilities Act) trailer conforms to all applicable portions of the ADA Accessibility Guidelines (ADAAG). In addition to being a preferred restroom for events, this unit is perfect for certain business remodels requiring restroom facilities that meet ADAAG requirements\*.

Whether used for a special event or an emergency situation, Royal Restrooms provide individuals with the comforts of home in clean, private, and spacious stalls featuring:

- Flushing Porcelain Toilets
- Sink with Running Water
- Vanity and Mirror
- Air Conditioning or Heat
- Low Level Outdoor Lighting
- Occupancy Light Indicator

The unique design of Royal Restrooms gives them the mobility to go virtually anywhere. This combo trailer is completely self-contained and is operable using a (2) 110 volt outlet (20 amps each) or generator for the lights, heat or air conditioner, as well as, propane fuel supplying an on-demand water heater. Water is supplied by a spigot and garden hose or a 100 gallon on-board fresh water holding tank. The unit houses a 150 gallon waste holding tank. With the option of diverting the shower water (grey water) out through a separate drain connection.

Rental options include daily, weekly, and long-term rentals, generators, additional fresh water holding tanks, and restroom attendant. Pricing and availability may be obtained by contacting Royal Restrooms California.

**877-922-9980**

**California@RoyalRestroomsCA.com**

**www.RoyalRestroomsCA.com**



**Festivals • Camp Grounds • Special Events  
Film/Music Production • Disaster Relief  
Job Sites • Business/Residential Remodels**

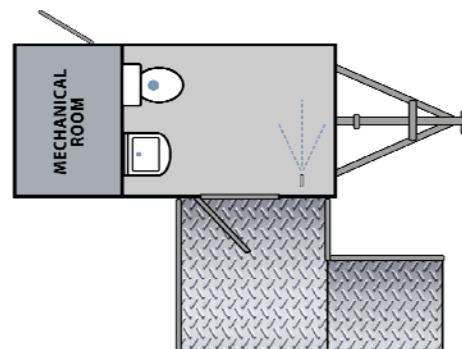

## Unit Dimensions

Length: 18' (including trailer tongue &)

Width: 12' (ramp down)

Height: 10' 6" (from ground to top of A/C unit)

Dry Weight: Approx. 2,800 lbs.

Licensed and Insured